

Torque-Limiting Tapping Head



Lucas Rivers

Design And Material Selection

- Sixteen clutch iterations
- 17-4 PH used for all but two components requiring machining

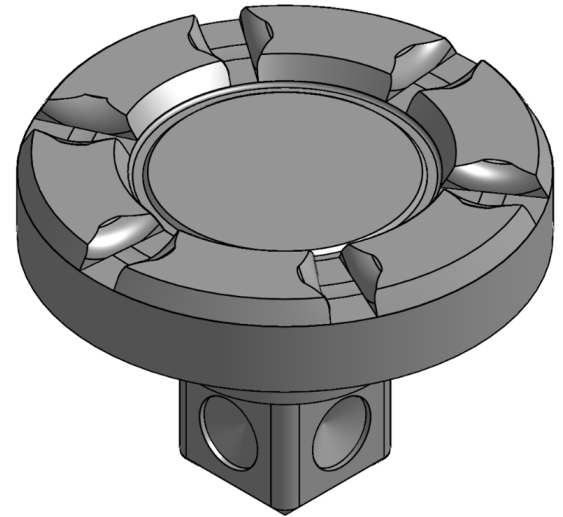
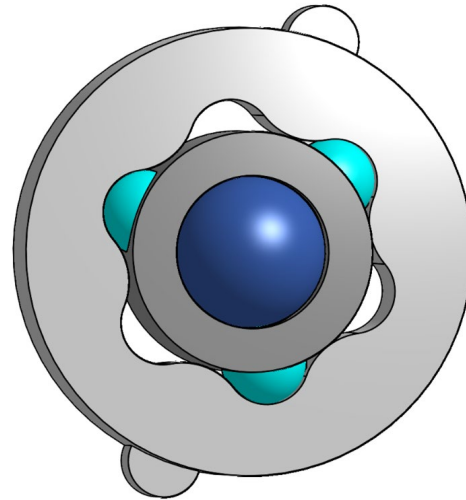
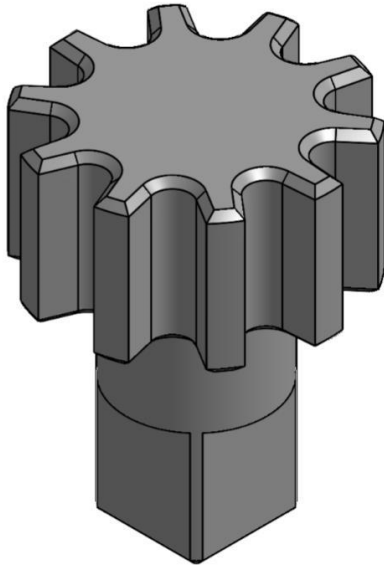

Largest Delays

- Boring bar instability
- Post processor compatibility
- 4th-axis rotary table mounting

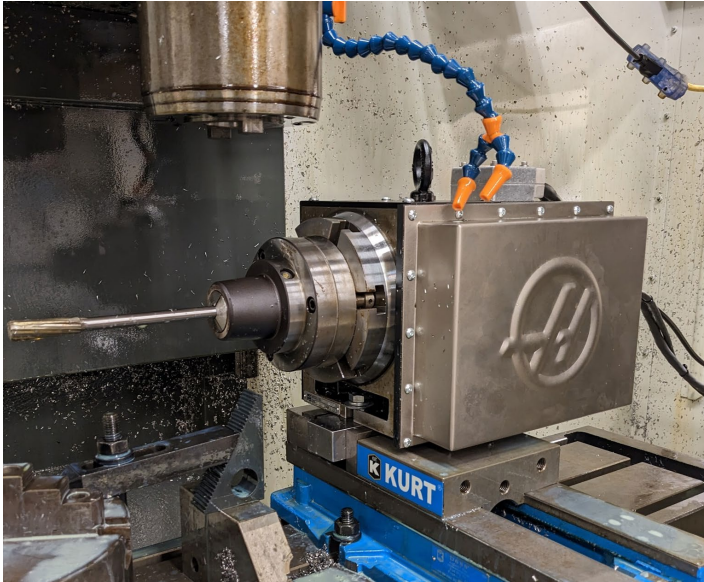

Testing



Testing

- Plotted torque values throughout entire adjustment range
- Attempted to break taps

Torque VS. Preload

